

C7 Series DC Contactor Specification

| | |
|---------------------|---------------------------------------|
| Customer | General Specification |
| Product Name | DC Contactor |
| Part Number | C7-500T-P C7-500TH-P C7-500TC-P |
| Date | 2020/04/01 |
| Validity | 2 Years |
| Version | 2020V1.0 |

Feature

- **Safe** : Fully sealed with epoxy resin, contact and coil will not be oxidized, product performance is not affected by external environment, no arc outbursts, can be worked in explosive and harmful environment.
- **Reliable**: Adopt DC high voltage non-polarity design, the breaking capacity is higher and more reliable, convenient and reliable installation or wiring.
- **Good for environment**: All components meet the latest ROHS environmental requirements.
- **Application** : Ordinary, quick charging, auxiliary contactor. Can be used in EV, charging equipment, photovoltaic system, etc.
- **Approval**: UL, CE

Ordering

C7 - 500 T H - P /XXX

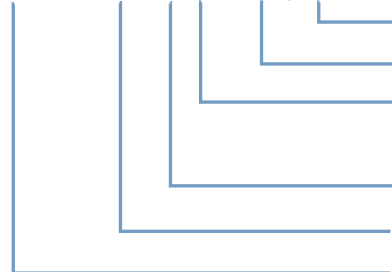

Customer number

Rated control supply voltage U_s : (P: 12/24VDC)

Auxiliary contact type: (H: with normally open, C: with normally closed
Nil: without)

Contact material: T: Alloy

Rated current 500: 500A

Company abbreviation:

C: DC Contactor 7

: Design number

Basic Parameter

| Contact parameter | | |
|-------------------|--|---------------------|
| Main contact | Rated operational current Ie | 500A |
| | Rated operational voltage Ue | 12~1000VDC |
| | Min. load | 1A12VDC |
| | Main contact type | 1SH (SPST NO DM) |
| | Nominal resistance of main circuit | MAX 30mV (@100A) |
| | Main contact mounting | M8 external thread |
| | Connecting torque | 10~12N·m |
| | Max. switching current (more than one cycle) | 2500A300VDC |
| Auxiliary contact | Max. current | 30VDC 2A; 125VAC 3A |
| | Min. current | 8VDC 100mA |
| | Contact resistance | <0.15Ω |

| Coil parameter | |
|-------------------------|------------------------|
| Rated voltage Us | 12/24VDC |
| Operating voltage range | 9~36 VDC |
| Pick up voltage | 8~9 VDC |
| Release voltage | 6~7 VDC |
| Coil power | holding: 3.2W |
| Inrush current | 3.8A (0.1s)(@12V) |
| Holding current | 0.267A@12V; 0.133A@24V |
| Pick up time (@Us) | ≤45ms |
| Releasing time (@Us) | ≤10ms |
| Bounce time (@Us) | ≤5ms |

Note: The above parameters are normal temperature rating, if other parameters needed, can customize.

| Life characteristics | | |
|--|------|---------------|
| Mechanical Life | | 300,000 |
| Resistivity load life (L/R≤1ms) | | See next page |
| Capacitive load life (RC=1ms , only for connecting) | 600A | 30,000 |
| Note: For capacitive load life, when the contactor is used to control the main circuit of charge and discharge, the pre-charge circuit should be added. If there is no pre-charging path, a transient large current will be generated when the contactor closes, which may cause the contactor to stick. | | |

| Electrical characteristics | |
|-------------------------------|-----------------|
| Dielectric withstand voltage | AC 3000V |
| Insulation resistance | ≥1000MΩ@1000VDC |
| Nominal insulation voltage Ui | 1000V |

| Environmental characteristics | | |
|-------------------------------|----------------|---------------------------|
| Shock | Stability test | 196m/s ² (20G) |
| | Strength test | 490m/s ² (50G) |
| Resistance to vibration | | 10~2000Hz, 20G |
| Operating ambient temperature | | -40℃~+85℃ |
| Operating ambient humidity | | 5%~85% RH |
| IP Grade | | IP67(inner space) |
| Altitude | | ≤4000m |

| Other | |
|---|----------------------------------|
| Weight | Approx.550g, with auxiliary 555g |
| The cross sectional area of an external conductor | ≥185mm ² |
| Case mounting hole torque | 2.5~3.5 N·m |

Short overload capacity curve

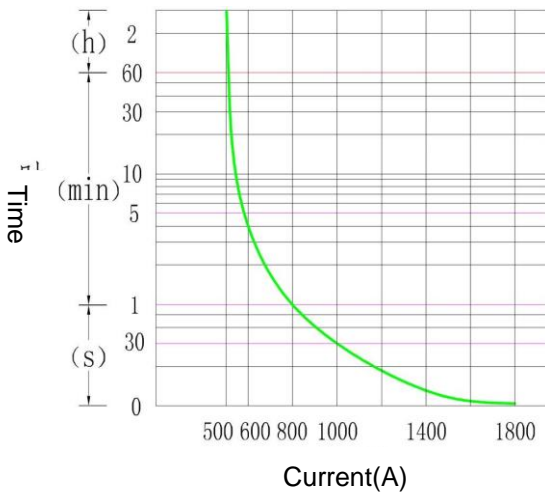

Cut-off life curve of resistive load

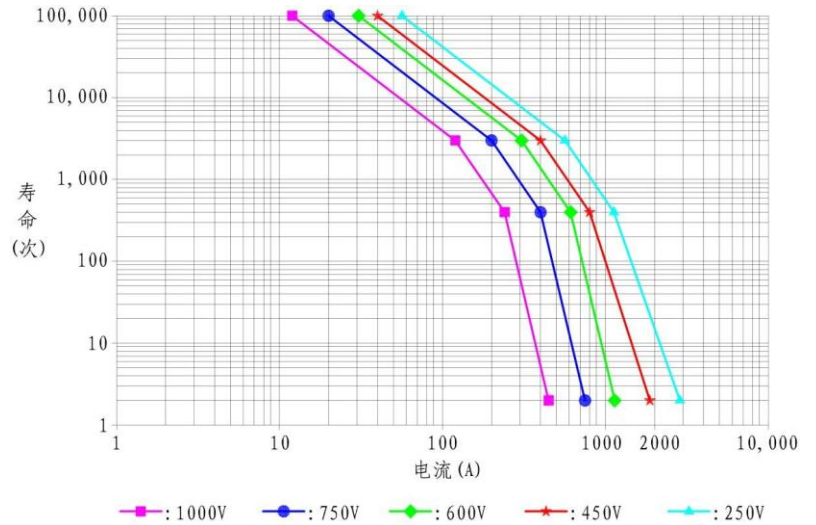

Note: Except for special note, the ambient temperature of electrical durability test is 23°C, and the on-break ratio is: 1s: 9s

Outline and wiring schematic diagram

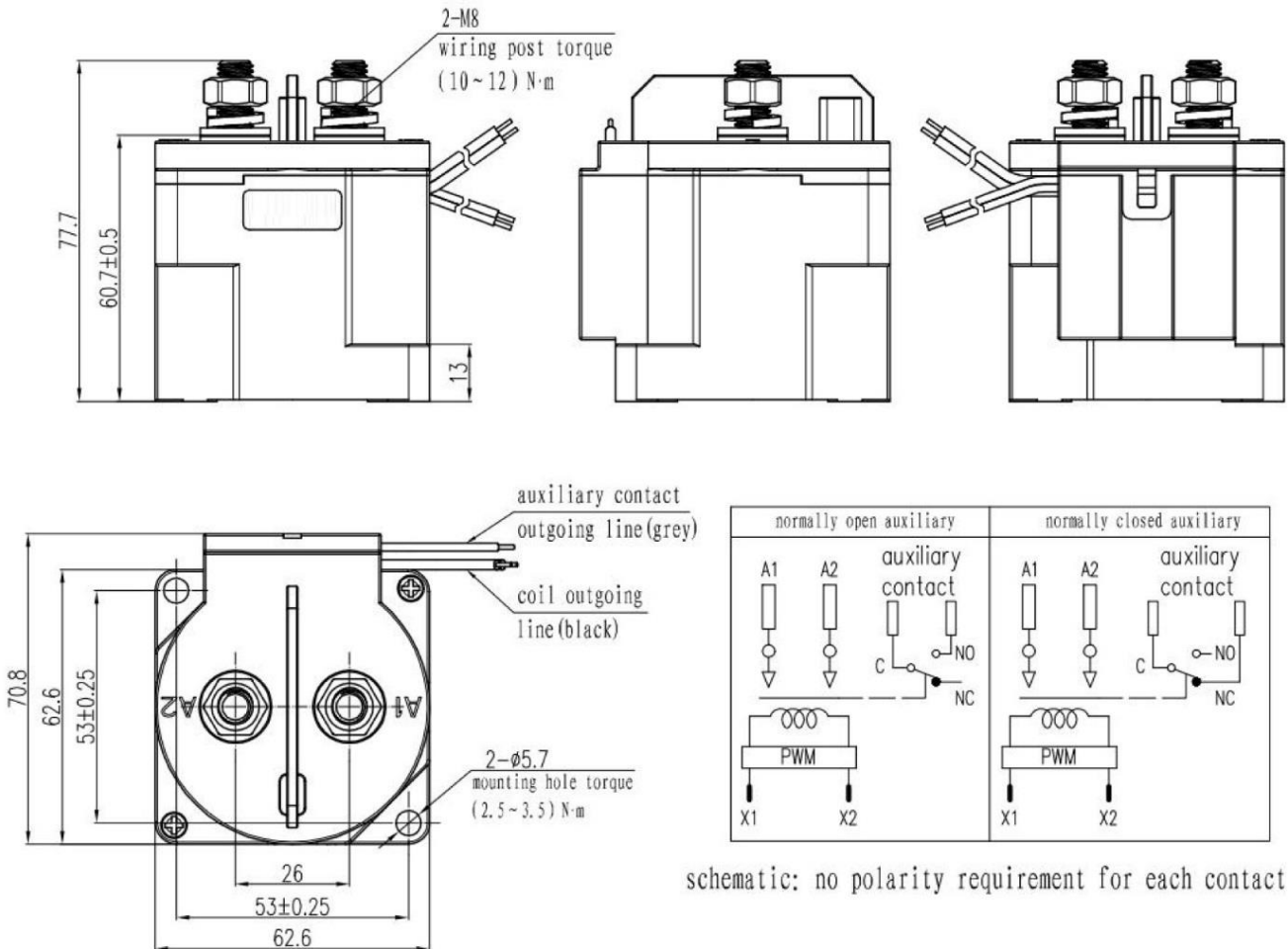

schematic: no polarity requirement for each contact

Note: Control coil wire length $300\pm 20\text{mm}$

Product without tolerance, when $\leq 10\text{mm}$, tolerance $\pm 0.3\text{mm}$

When dimension between $10\sim 50\text{ mm}$, tolerance $\pm 0.5\text{mm}$

When dimension $\geq 50\text{mm}$, tolerance $\pm 0.8\text{mm}$

Notice

1. Using spring washers to prevent loose screws when installing contactors.
2. The torque of tightening screws should be within the specified range. Exceeding the max. torque may lead to product breakage.
3. There is no polarity requirement for the main contact and the lead of the control coil of this contactor.
4. The specification products with energy saving boards are equipped with a reverse surge absorption circuit, so there is no need to use surge protector any more. We suggest that the specification products without energy saving boards should be installed with varistors as surge protector, and the use of diodes should be avoided, because this will reduce the cutting ability of the products.
5. Do not use products that have been dropped.
6. Avoid placing the product near a strong magnetic field (near a transformer or magnet) or near an object with thermal radiation.

7. Electrical life

This contactor is a high-voltage DC switch. In its final breakdown mode, it may lose its proper cutting function, so it should not be used beyond its switching capacity and life parameters (please treat this contactor as a product with specified life, and replace it if necessary). Once the contactor loses its disconnection ability, it may not work properly, so design the circuit diagram to ensure that the power can be cut off within one second.

8. Diffusion life of internal gas

The contactor adopts sealed bin contact, and the bin is filled with gas. The diffusion life of the gas is determined by the temperature in the contact bin (ambient temperature + temperature rise generated by contact electrification), so the ambient temperature should be $-40^{\circ}\text{C} \sim +85^{\circ}\text{C}$

9. If the coil and contact of the contactor are continuously passed at the rated voltage (or current), the power was cut off and switched on immediately. At this time, as the temperature of the coil increases, the resistance of the coil will increase, which will increase the product's closed voltage, may cause excess of rated closed voltage. In this case, the following measures should be taken: Reduce the load current, limit the duration of continuous power or use coil voltage higher than the rated suction voltage.

10. For resistive load, the rated main contact rating shall apply, and for inductive load (L load) with $L/R > 1$ millisecond, an inrush current protection device shall be connected to the inductive load in parallel.

11. The drive circuit power of the product coil must be greater than that of the product coil, otherwise the cutting ability of the product will be reduced.

12. Be careful not to let sundries and grease on the main lead out end, and the external wiring terminal should be in reliable contact with the main lead out end of the product, or it may cause the lead out end heat.

13. For the specification products with energy saving plate, after being connected, the coil will start to switch automatically after about 0.1 seconds. Do not repeatedly turn off at that position, which may damage the contactor.