

C7 Series DC Contactor

SPECIFICATION

Product name	High Voltage DC Contactor
Product model	C7-250T-P C7-250TH-P C7-250TC-P C7-250TZ-P C7-250T-PW C7-250TH-PW C7-250TC-PW C7-250TZ-PW
Date	September 2023
Period of validity	2 Years
VERSION	2023V1.0

Product Features

- Safety:** The fully sealed structure of epoxy resin is used, and the contacts and coils will not oxidize. The product performance is not affected by external environment, and there is no arc external spraying. It can work in explosive and harmful environments;
- Reliable:** Adopting DC high voltage polarity free design, with higher breaking capacity and reliability, and convenient and reliable installation/wiring;
- Environmental protection:** All components comply with the latest EU RoHS environmental requirements;
- Energy saving:** Adopting PWM control technology to effectively control the power and action characteristics of the control coil, making it more energy-efficient;
- Purpose:** Charging circuit, auxiliary circuit or main circuit control relay; Can be used for electric vehicles, charging equipment, photovoltaic systems, etc;
- Certification:** This product has obtained UL certification, CE certification, and TUV certification.

Model Description

C7 - 250 T H - P W /XXX

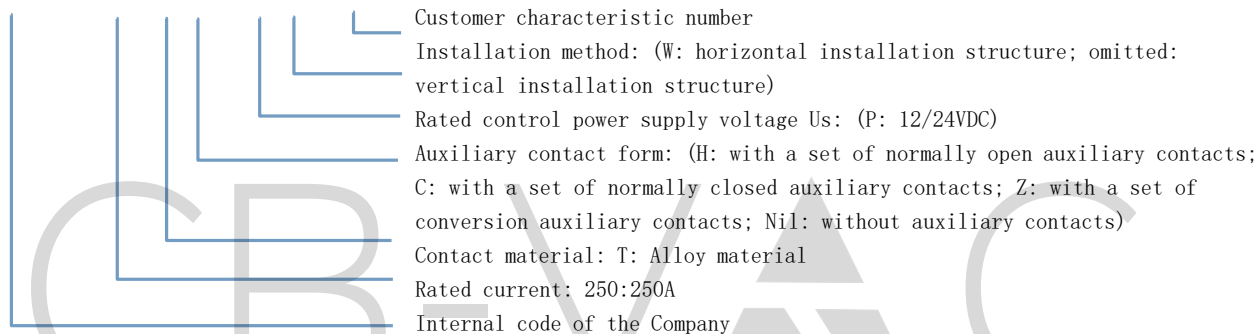

Basic parameters

Contact parameters			Coil parameters	
M a i n c o n t a c t	Rated operational current Ie	250A (copper bars 75mm2)	Rated voltage Us	12/24VDC
		400A (copper bars120mm2)	Operating voltage range	8~36 VDC
		500A (copper bars200mm2)	Pull-in voltage	7~8 VDC
	Rated operational voltage Ue	12~1500VDC	Release voltage	5~6 VDC
	Minimum load	1A12VDC	Coil power	Holding: 2W
	Main contact form	1SH (Double acting closing contact)	Starting current	3A (0.1s) (@12V)
	Main circuit resistance	0.2 mΩ (@250A)	Holding current	0.17A@12V; 0.085A@24V
	Main contact installation method	M8 External thread	Pull-in time (@Us)	≤45ms
Wiring installation torque	10~12N·m	Release Time (@Us)	≤10ms	
Maximum switching current (more than once)	2500A320VDC	Action time (@Us)	≤5ms	
AUX con tact	Maximum current	30VDC 2A; 125VAC 3A		
	Minimum current	8VDC 100mA		
	Contact resistance	<0.15 Ω		

Note:

The above parameters are all rated values at room temperature. If other parameter requirements are needed, it can be customized.

Lifetime characteristics		
Mechanical life	300,000 times	
Resistive load life (L/R≤1ms)	250A500V:6000 times 250A750V:3000 times 250A1000V:1000 times 120A1200V:1000 times 80A1500V:1000 times	
Capacitive load life (RC=1ms, connected)	600A	50,000 times
Note: capacitive load description: When the contactor is used for charging and discharging main circuit control, a pre charging circuit should be added; If there is no pre charging circuit, transient high current will be generated at the moment of contactor closure, which may cause the contactor to stick.		

Environmental		
Impact resistance	Stability test	196m/s ² (20G)
	Strength testing	490m/s ² (50G)
Anti vibration	10~2000Hz, 20G	
Ambient Temperature	-40°C~+85°C	
Working environment humidity	5%~85% RH	
Protection grade	IP67(Internal space)	
Applicable altitude	≤4000m	

Electrical characteristics	
Dielectric withstand voltage	AC3000V
Insulation resistance	≥1000MΩ @1000VDC
Rated insulation voltage Ui	1000V

Other characteristics	
Weight	425g, 430g with auxiliary
Cross sectional area of external conductor	≥75mm ²
Housing mounting hole torque	2.5~3.5 N·m

Short time overload capacity curve

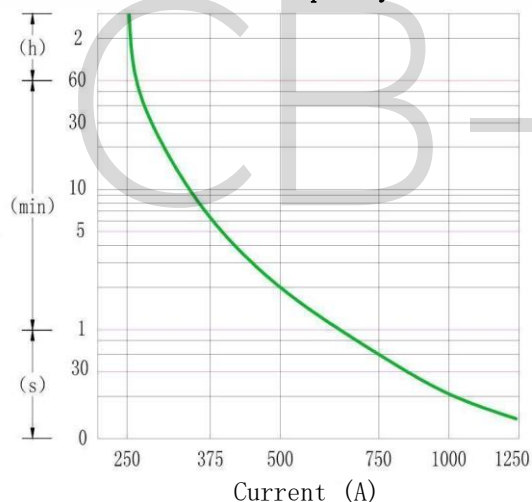

Product appearance and wiring schematic diagram

Vertical installation

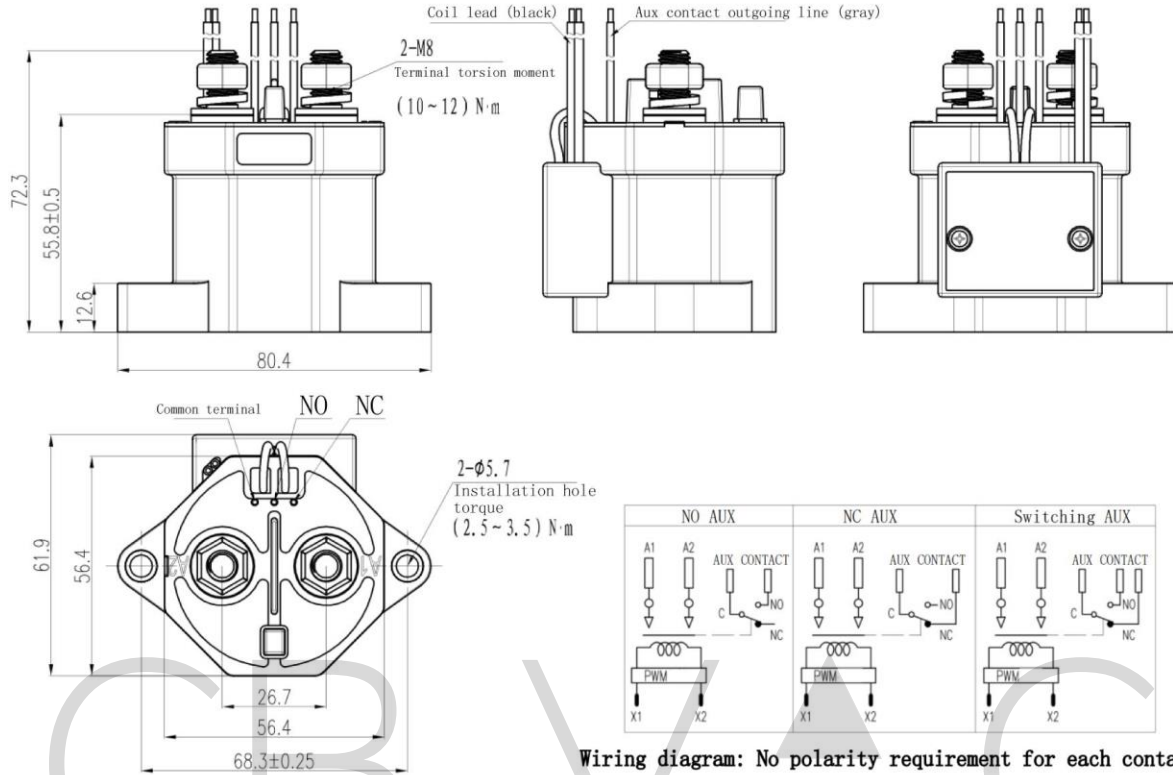

Horizontal installation

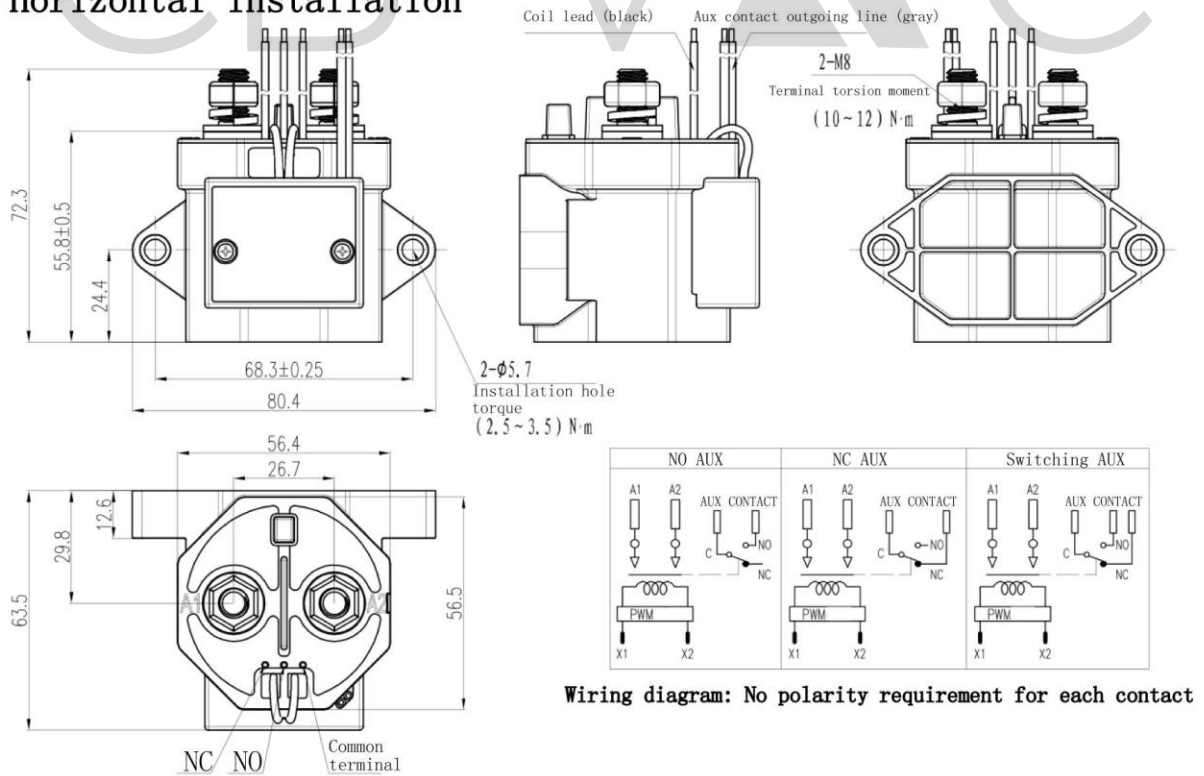

Note: The length of the control coil wire is 300 ± 20 mm;
The product does not indicate tolerance dimensions, and when ≤ 10 mm, the tolerance is ± 0.3 mm;
When the size is between (10-50) mm, the tolerance is ± 0.5 mm;
When the size is ≥ 50 mm, the tolerance is ± 0.8 mm.

Note:

1. When installing contactors, washers should be used to prevent screws from loosening.
2. The torque range for tightening screws is specified below. Exceeding the maximum torque value can cause product breakage.
3. There are no polarity requirements for the main contact and control coil leads of this contactor.
4. Products with energy-saving boards are equipped with a reverse surge absorption circuit, so there is no need to use surge protectors. We recommend installing varistors as surge protectors for products without energy-saving boards. Diodes should be avoided as this will reduce the product's cutoff energy.
5. Do not use dropped products.
6. Avoid installing the product in areas with strong magnetic fields (near transformers or magnets) or near objects with thermal radiation.
7. Electrical lifespan
This contactor is a high-voltage DC switch, and in its final breakdown mode, it may lose its proper cut-off function. Therefore, do not use it in a state that exceeds its switching capacity and lifespan parameters (please treat this contactor as a product with a specified lifespan and replace it if necessary). Once the contactor loses its ability to disconnect and cut off, it may not work properly. Therefore, it is necessary to design a circuit diagram to ensure that the power supply can be cut off within 1 second. This contactor adopts sealed chamber contacts, which are filled with gas. The diffusion life of the gas is determined by the temperature inside the contact chamber (ambient temperature+temperature rise generated by contact electrification), so it should be ensured that the ambient temperature is -40 to+85.
8. Diffusion Life of Internal Gas
9. If the coil and contact of the contactor are continuously connected to the rated voltage (or current), and the power is cut off and immediately connected, the resistance of the coil will increase due to the increase in coil temperature, which may cause the product's pull-in voltage to increase, potentially exceeding the rated pull-in voltage. In this case, the following measures should be taken: such as reducing the load current, Limit the continuous power on time or use a coil voltage higher than the rated pull-in voltage.
10. When resistive load is applied, the rated parameters of the main contact in the rated value are applicable. If inductive load (L load) is used and L/R is greater than 1 millisecond, a surge current protection device should be connected in parallel for the inductive load.
11. The driving circuit power of the product coil must be greater than the power of the product coil, otherwise it will reduce the cutting capacity of the product.
12. Be careful not to let debris and oil stains get on the main outlet, and the external wiring terminal should be in reliable contact with the main outlet of the product, otherwise it may cause severe heating at the outlet. Please connect various wire harnesses and busbars according to the following methods.
13. For products with energy-saving boards, after about 0.1 seconds of connection, the coil will automatically switch. Do not repeatedly turn off at that position, as this may damage the contactor.